

PRODUCT BULLETIN

Freight

REPAIR CARTRIDGES – Rebuild Angle Cocks, Dirt Collectors and End Cocks quickly.

With extensive product development and testing facilities, NYAB is committed to developing and supplying superior quality components. We provide technical support to assure that the right component is selected for every application, and maintain a network of field service personnel as part of our customer service commitment.



Key Repair Cartridge Benefits

- **Save time** – repairable parts can be replaced without removing the valve from the car's piping
- **Reduce cost** – fewer parts and less inventory
- **Eliminate lost parts** – hex screws are captivated
- **Reliable and rugged** – corrosion free, non-abrasive, positive sealing surfaces
- **Available for all product variants** to replace rubber repair kits

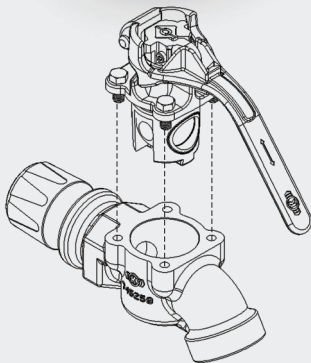

Cartridge based Angle Cock (CBAC) – hex screws torqued to 18-26 ft-lbs.

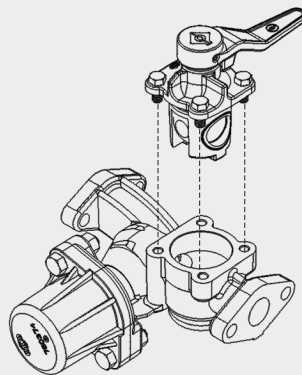

Cartridge Based Dirt Collector (CBDC) – hex screws torqued to 18-26 ft-lbs.

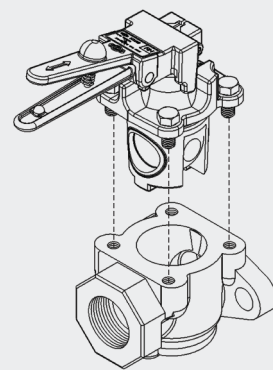

Cartridge Based End Cock (CBEC) – hex screws torqued to 20 – 24 ft-lbs.

Engineered to Outperform (E₂O) quality, superior service, competitive prices

NYAB's products deliver durability and reduce costs. For more information on product benefits, visit www.nyab.com or contact Vince Moore at **315-786-5271**.

E₂O Engineered to Outperform

NEW YORK AIR BRAKE

