

Technical Guide for the Product User

1-1/4" SINGLE PIECE REPAIR CARTRIDGES FOR DIRT COLLECTORS (P/N 795051 AND P/N 795052)

PRODUCT DESCRIPTION

Cartridge Based Angle Cock (CBAC) allows for ease of repair as all internal parts can be replaced quickly without removing the dirt collector from the car piping.

P/N 795051

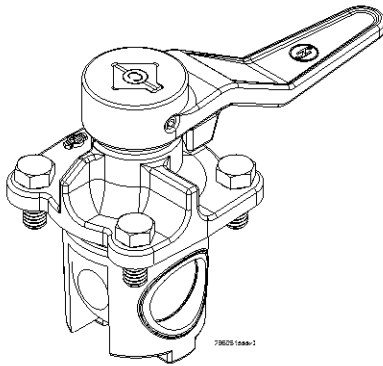

(Used with Dirt Collectors
704863, 771502, 773716
and 778892)

P/N 795052

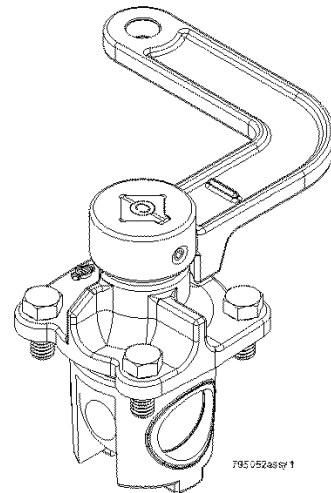

(Used with Dirt Collector 786381)

FEATURES

- One Piece Composite Ball and Key which provides:
 - Corrosion free, non-abrasive, positive sealing surface
 - Reduced time and cost to perform rebuilding due to fewer parts
 - Lighter weight
- Captivated hex head cap screws allow for ease of assembly by eliminating lost screws during installation.
- Ease of maintenance as all internal repairable parts can be replaced without removing the dirt collector from the car piping.
- Approximate net weight of 2-1/4 lbs

1-1/4" SINGLE PIECE REPAIR CARTRIDGE FOR DIRT COLLECTOR

INSTALLATION INFORMATION

Standard

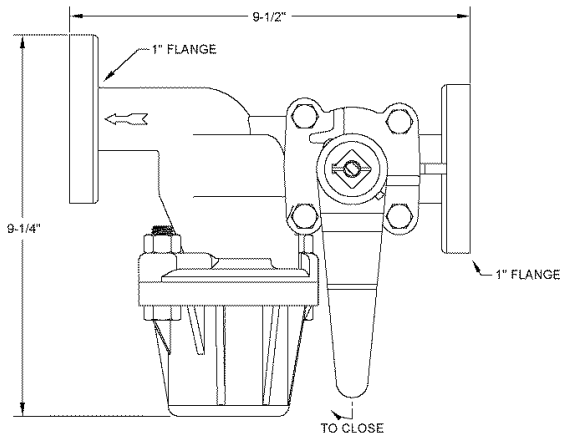
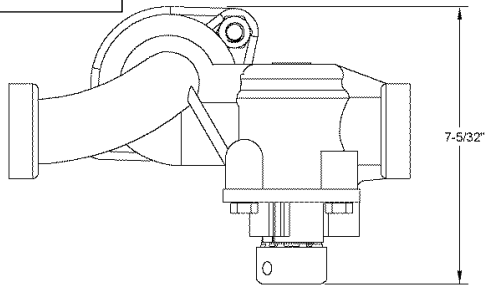

L-Shaped Handle

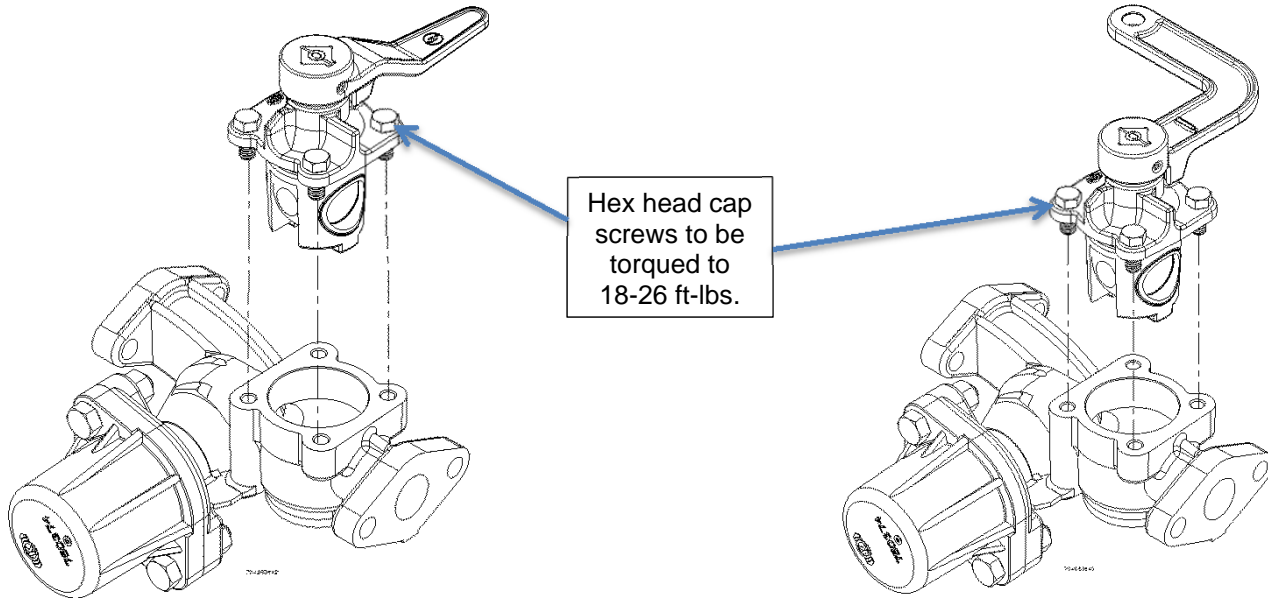
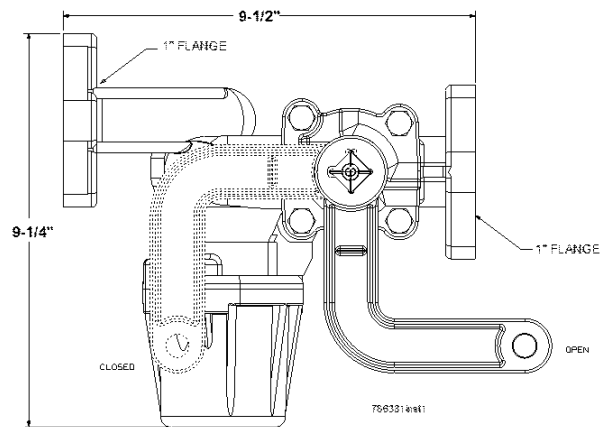
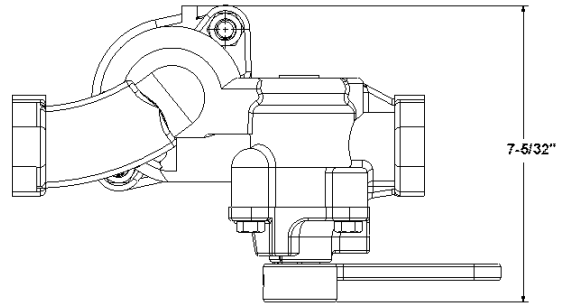

NEW YORK AIR BRAKE, LLC

www.nyab.com

748 Starbuck Avenue, Watertown, New York 13601

Telephone: 315-786-5200 . 1-888-TEN NYAB

FAX: 315-786-5673 (Engineering)

315-786-5675 (Marketing)

Copyright © NYAB. All rights reserved, including industrial property rights applications. NYAB retains any power of disposal, such as copying and transferring.



Knorr-Bremse Group

TG-58 / April 30, 2019 / Rev.0

Page 2 of 2