

Technical Guide for the Product User

1-1/4" SINGLE PIECE REPAIR CARTRIDGES FOR END COCKS (P/N 795050 AND P/N 795049)

PRODUCT DESCRIPTION

Cartridge Based Angle Cock (CBAC) allows for ease of repair as all internal parts can be replaced quickly without removing the end cock from the car piping.

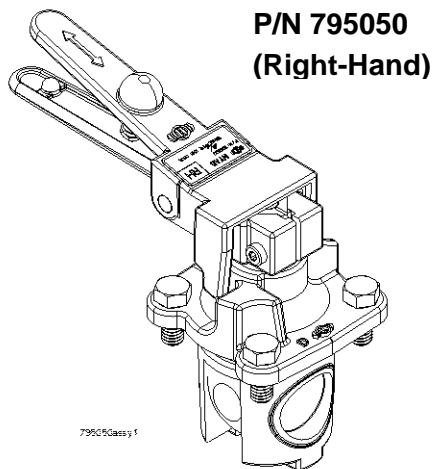

**P/N 795050
(Right-Hand)**

(Used with End Cock
705503)

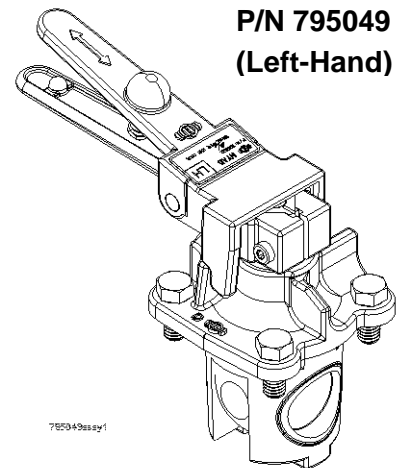

**P/N 795049
(Left-Hand)**

(Used with End Cock
705502)

FEATURES

- One Piece Composite Ball and Key which provides:
 - Corrosion free, non-abrasive, positive sealing surface
 - Reduced time and cost to perform rebuilding due to fewer parts
 - Lighter weight
- Captivated hex head cap screws allow for ease of assembly by eliminating lost screws during installation.
- Ease of maintenance as all internal repairable parts can be replaced without removing the end cock from the car piping.
- Approximate net weight of 3 lbs

1-1/4" SINGLE PIECE REPAIR CARTRIDGE FOR END COCK

INSTALLATION INFORMATION

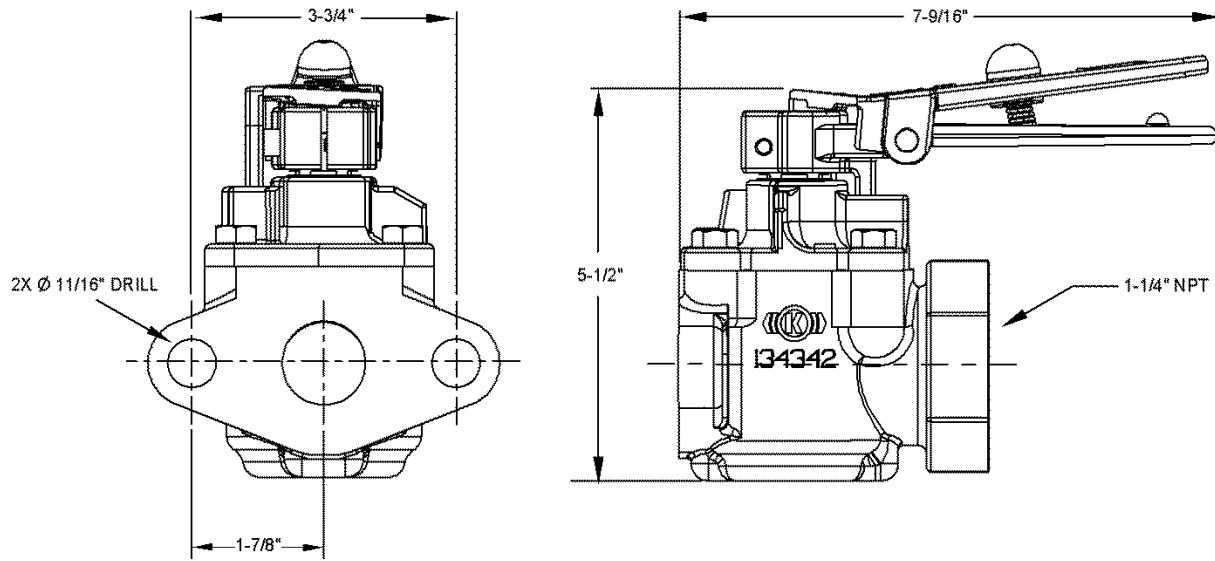

Right-Hand

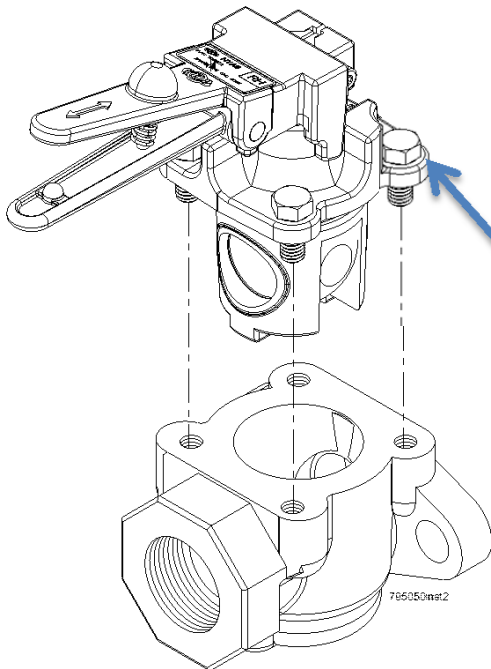

Left-Hand

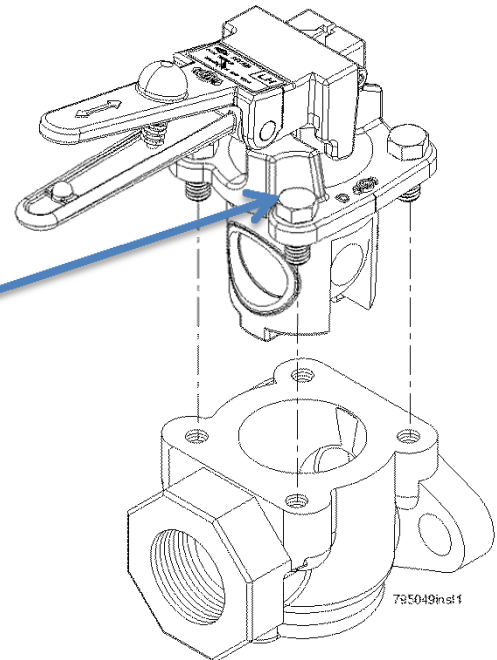

Hex head cap screws
to be torqued
to 20 – 24 ft-lbs

NEW YORK AIR BRAKE, LLC

www.nyab.com

748 Starbuck Avenue, Watertown, New York 13601

Telephone: 315-786-5200 . 1-888-TEN NYAB

FAX: 315-786-5673 (Engineering)

315-786-5675 (Marketing)

Copyright © NYAB. All rights reserved, including industrial property rights applications. NYAB retains any power of disposal, such as copying and transferring.



Knorr-Bremse Group

TG-59 / May 6, 2019 / Rev.0

Page 2 of 2